

HRCS: High Resolution Counting Scale

Features and Specifications

- **Counting Application:** Easy-to-use sampling routines including a one key press bulk process to a two key press dribble sampling routine where the sample key is pressed once all sample parts are on the scale (dribble is the default mode) Positive and negative sampling both possible
- **Check Counting:** Ideal when batching product by count items rather than weight
- **Count Accumulation:** Designed to quickly totalize all counted items that have been processed or counted on the scale
- **40 PLU Data Storage:** Stores and recalls piece weight and tare weights within the scale. Numeric only up to 7 digits. Keypad required.
- **Second Remote Base:** Auto or key activated remote base switching. Keypad is required.
- **Software:** B-Tools compatible
- **Time and Date:** Battery backed up time/date/year (12 hour or 24 hour format)
- **Calibration:** Up to five points of calibration, stored within the indicator
- **Minimum Sample Size:** Limits the sample size that can be entered in the scale
- **Required Accuracy:** Allows supervisor to set the required scale accuracy subject to the environment and components being weighed (99.5% to off)
- **Minimum Sample Weight:** Limits the operator on the minimum sample weight they can use to get an accurate piece weight (turning this function off reduces the probability of achieving the required accuracy)
- **Data Base Edit:** Allows supervisor to store up to 40 known piece weights and tare weights along with upper and lower limits if check counting is activated
- **Auto Component Latching:** Ideal when weighing extremely light components to help stabilize the weight reading after counting
- **Auto Base Switching:** Allows the supervisor to select which base they want to use for sampling when a second base is installed

Advanced Settings

- **Required Sampling Routine:** Bulk or dribble sampling (default setting is dribble)

Approvals

UL/c-UL, CE, EC, RoHs, RCM approved



HRCS: High Resolution Counting Scale

Physical Attributes

- **Operating Temperature:** 41° F to 104° F / +5° C to 40° C (approvals) at 10 to 90% humidity
-4° F to 140° F / -20° C to 60° C (industrial) at 10 to 90% humidity
- **Foot Adjustment:** Water resistant anti-slip rubber foot with finger grip locking ring to allow up to 0.75" (19 mm) height adjustment
- **Carry Handles:** Carry handles allow this scale base to be easily carried around
- **Construction:** High resolution Quartzell mounted inside a robust aluminium die-cast clamshell base with 1100% overload and shock load protection
Indicator is protected inside a rugged ABS indicator housing that is most commonly mounted to the front of the base. This indicator can also be easily removed for wall or deck mounting. Max workable distance for indicator to work away from the base is 50 ft

HRCS: High Resolution Counting Scale

Options

- Ball top for 12" x 14" (305 x 350mm) base
- Draft shield (up to 10 lb / 5 kg only)
- Clamp down plate
- Printers
- Numeric keypad
- Scanners
- Remote analog card
- Wireless card
- Stack light
- Indicator wall or desk brackets
- Underhook (only used on bases up to 10lb / 5kg)
15" or 23" (380 x 585 mm) Stainless steel indicator columns
- Underhook (1-10 lb/1-5 kg, 2-10 lb/1-5 kg, 70 lb/35kg) 9" x 12" base only

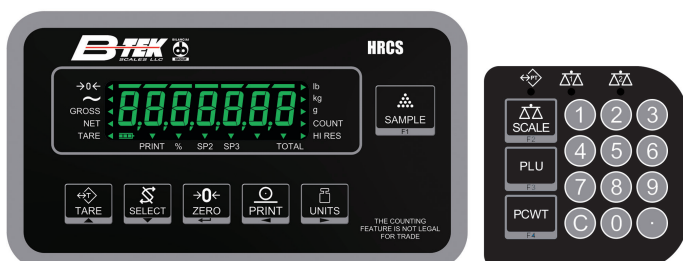

*Shown with optional keypad

HRCS: High Resolution Counting Scale User Interface

- **Operational Keys:** Six metal domed keys with audible feedback - Sample F1, Tare, Select, Zero, Print, Units (lb, kg, g, oz, and custom)
- **Optional Remote Keypad:** 15 key remote keypad that can easily be attached to any HRCS, giving expanded functionality Required when using a second remote base, when using internal stored PLU database, or entering known piece or tare weights
- **Key functions:** 0 to 9 numeric keys, cancel, decimal point, scale switching, PLU, piece weight key
- **Base Size and Capacity:**
 - 1 lb to 2 lb (500 g to 1 kg) Max 9" x 12" with 6" dia. weight platter
 - 2 lb to 10 lb (1 kg to 5 kg) Max 9" x 12" with 6" dia. weight platter
 - 20 lb to 70 lb (5 kg to 35 kg) Max 9" x 12"
 - 20 lb to 70 lb (5 kg to 35 kg) Max 12" x 14"
 - 70 lb to 175 lb (35 kg to 80 kg) Max 12" x 14"
- **Digital Filtering:** Three digital filters stored within the indicator with adjustable average, constant and threshold filter settings
- **Display Rate:** 100Hz
- **Resolution:** 100,000 divisions center of pan, stable room temperature
Up to three range multi interval or multi range can be configured
- **Internal Resolution:** 1 billion counts (1,000,000,000 internal counts)
- **Load cell Technology:** High accuracy digital Quartzzell transducer
- **Overload Protection:** 1100% overload protection
- **Corner Loading:** Spring breakaway system is activated at 120% full capacity or 60% corner only load
- **Recommended Minimum Piece Weight by Base Type (Sample Size of 50):**
 - 2 lb (1kg) min piece weight: 0.000004 lb (2 mg) min sample weight: 0.00022 lb (0.1 g)
 - 10 lb (5kg) min piece weight: 0.000022 lb (10 mg) min sample weight: 0.0011 lb (0.5 g)
 - 70 lb (35kg) min piece weight: 0.000154 lb (70 mg) min sample weight: 0.0077 lb (3.5 g)
 - 175 lb (80kg) min piece weight: 0.000352 lb (160 mg) min sample weight: 0.0176 lb (8 g)
- **Count Accuracy:** Fully configurable up to 99.5% subject to environment and component size being sampled
- **Filter Setting:** Controlled within the indicator
- **Creep:** 0.001% of 100,000 divisions over a 30 minute period or 0.0005% of 200,000 divisions over a five minute timespan
- **Minimum Recommended Non Verifiable Division Size:**
 - 0.000001 lb (0.0005 g) for the 2 lb (1 kg) base
 - 0.000005 lb (0.002 g) for the 10 lb (5 kg) base
 - 0.00002 lb (0.01 g) for the 70 lb (35 kg) base
 - 0.00005 lb (0.02 g) for the 175 lb (80 kg) base
- **Division Size (Class III):** 0.0005 lb (0.1 g) for the 2 lb (1 kg) base (10,000d approved)

Display Operating Applications

- **Compatibility:** Supplied connected to one base as standard
Max number of bases allowed: two (one local base and a second or analog platform)
Can link to a second by utilizing (1) RS232 port
Can also link to an analog remote base (with up to six 360 ohm load cells) by installing an optional 5 VDC excitation analog base card and remote keypad
- **Indicator Display:** Green on black IBN display ideal for low lit areas. Easy to read seven digit 0.5 in tall seven segment display. Green under, over and accept segment bar.
- **Metrology Data:** Stored within the indicator
- **Indicator to Base Communications:** Local base connection: one dedicated RS232 connection using a keyed RJ45 connector found on the rear of the indicator
Second base: to be wired in through the RS232 comm port
Second analog base: wired into dedicated second analog base connector. Requires optional 5V ex card fitting along with remote keypad
- **HRCS Ports:**
Comes standard with (2) Serial ports, (1) Ethernet, (3) Inputs and (3) Outputs
(2) RS232 serial ports (green connector)
(1) Mini USB VCP port: connected in parallel with COM2 or consumes COM2 if used
(1) Ethernet port (local base: client or server. Dual base: server only)
(1) Analog port (green connector) only active when optional 5V analog card is fitted
(1) Side RJ45 connector dedicated for remote keyboard only
(1) 9V DC power socket to allow the base or indicator to be powered from the DC socket on the rear of the base or directly from the rear of the indicator
- **Power Options:** 100V to 240V AC 50/60 Hz switch mode power supply mounted to the rear of the base
Base can be powered using either a power jack on the rear of the base or to the rear of the indicator
- **Battery Power Option:** Factory fit NIMH rechargeable battery option to give up to 16 hours of continuous usage or remote battery option gives up to 25 hours' continuous usage

HRCS: High Resolution Counting Scale
 Drawings

9 in x 12 in

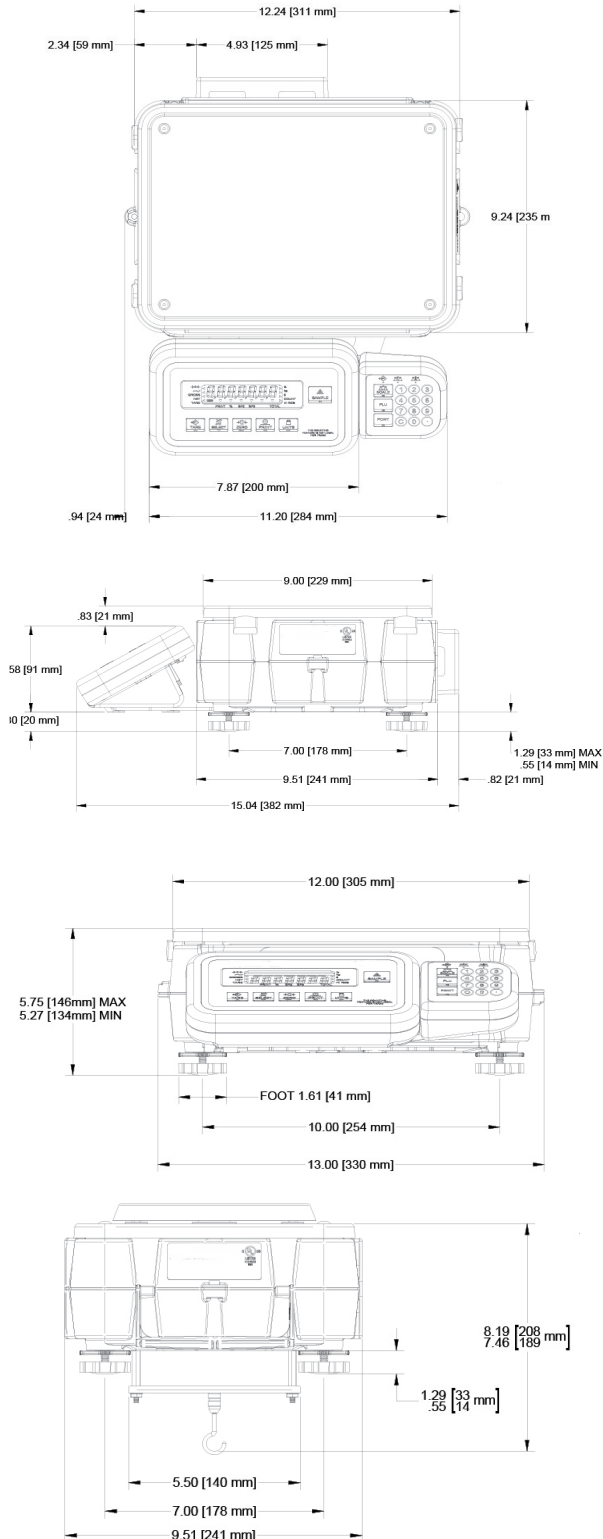

12 in x 14 in

